



111474 Grey
111476 Blue
111477 Red
UMB-922120-BL
UMB-922120-GR
UMB-922120-RED

Model

USE AND CARE GUIDE

9 FT. (2.72 m) TILTING UMBRELLA

Questions, problems, missing parts? Before returning to the store,
call Hampton Bay Customer Service
8 a.m. - 7 p.m., EST, Monday - Friday, 9 a.m. - 6 p.m., EST, Saturday



01 800 004 6633

HOMEDEPOT.COM

IMPORTER: SERVICIOS HOME DEPOT, S. DE R.L. DE C.V.
RICARDO MARGÁIN NO. 605, SANTA ENGRACIA, SAN PEDRO GARZA GARCÍA, NUEVO LEÓN, MÉXICO CP 66267
PHONE: 01 800 004 6633

THANK YOU

We appreciate the trust and confidence you have placed in Hampton Bay through the purchase of this umbrella. We strive to continually create quality products designed to enhance your home. Visit us online to see our full line of products available for your home improvement needs. Thank you for choosing Hampton Bay!

Table of Contents

| | | | |
|-----------------------------|---|-------------------------|---|
| Safety Information | 2 | Operation..... | 6 |
| Warranty | 3 | File a Claim | 7 |
| Pre-Installation | 3 | Care and Cleaning | 7 |
| Planning Installation | 3 | Troubleshooting | 7 |
| Package Contents | 4 | | |
| Installation | 5 | | |

Safety Information

 **WARNING:** This umbrella is designed for easy operation, sunshade and decorative purposes only. It is NOT recommended that this umbrella be used during periods of high wind and rain. Always take the umbrella down during high or gusting wind and rain, when not in use and in the off-season. Failure to do so may result in personal injury and/or property damage.

 **DANGER:** Keep children away from the umbrella during assembly to avoid injury.

 **CAUTION:** Placement of the umbrella over or near a swimming pool will cause premature fading, it goes against the normal conditions of use, especially to darker colors.

 **CAUTION:** If the crank becomes too hard to crank, check to see if the rope has come off the pulley. If you continue to turn the crank, the rope or crank handle could break.

Warranty

ONE YEAR LIMITED FRAME WARRANTY

WHAT IS COVERED

The Frame is warranted to be free of manufacturing defects for one year from purchase date. If the frame of your furniture fails (i.e. broken frame or weld) within one year of ownership, Hampton Bay will repair, provide replacement parts, or replace the product at our option. Frame finishes are warranted against blistering, cracking, or peeling for one year from purchase date. This is a residential use warranty only. Warranty is void for product used in commercial settings. This warranty is a limited warranty and applies to the original purchase only. Proof of purchase is required.

WHAT IS NOT COVERED

Failure caused by unreasonable or abusive use, fire, freight damage, acts of nature (such as, but not limited to freezing or high winds), suntan oil or other chemicals, normal fading, scratching or chipping of the finish, fading, weathering or staining or discoloration of furniture, accidental damage, repair, or modifications by customer, glass breakage, normal wear and tear are excluded from the warranty. Furniture used in commercial, contract or any other non-residential applications; clearance items, and display models are not covered under this warranty. In no event shall Hampton Bay responsibility exceed the value of the replacement part/product. Freight damage is not covered under this warranty. Freight and packaging charges to return a product or part are not covered under this warranty.

Contact the Customer Service Team at 01 800 004 6633 or visit www.homedepot.com.

Warranty printed in the manual is not valid for Mexico.

Pre-Installation

PLANNING INSTALLATION

Before beginning assembly of the product, make sure all parts are present. Compare parts with the package contents list and diagram on page 4. If any part is missing or damaged, do not attempt to assemble the product or return to the place of purchase. Contact our customer service toll free at 01 800 004 6633 for replacement parts or further instructions.



NOTE: We recommend that you insert the umbrella into an umbrella base or table (not included) for securing the umbrella.



DANGER: Keep children away from the umbrella during assembly to avoid injury.

TOOLS REQUIRED

No tools required.

HARDWARE INCLUDED

No hardware required for assembly.

Pre-Installation

PACKAGE CONTENTS

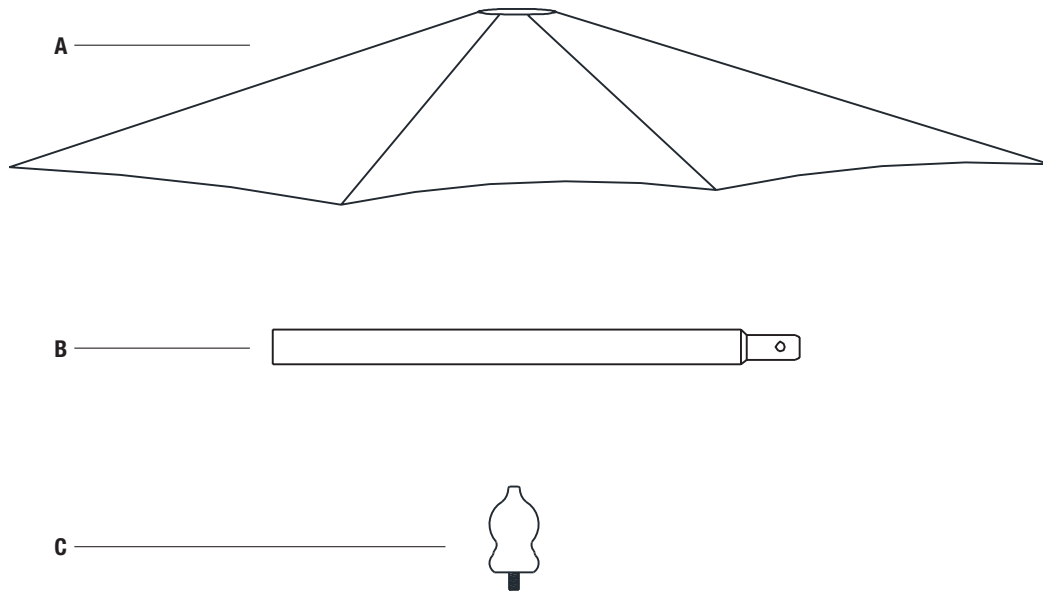

| Part | Description | Quantity |
|------|---------------------------|----------|
| A | Umbrella Frame and Canopy | 1 |
| B | Bottom Pole | 1 |
| C | Finial | 1 |

Installation

1 Attach the Finial

- Attach the finial (C) on top of the umbrella frame (A) (if unattached) by screwing the finial onto the threaded screw-in adapter on the top of the umbrella frame (A). Twist until secure but do not over tighten

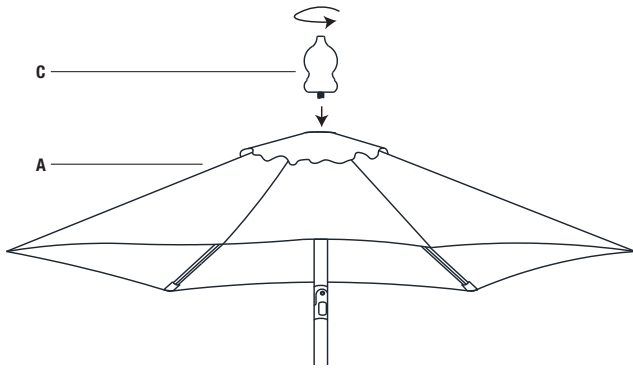

2 Assemble the Pole

- Insert the bottom pole (B) into the upper pole while pressing the snap button on the bottom pole (B) until the snap button locks into position.

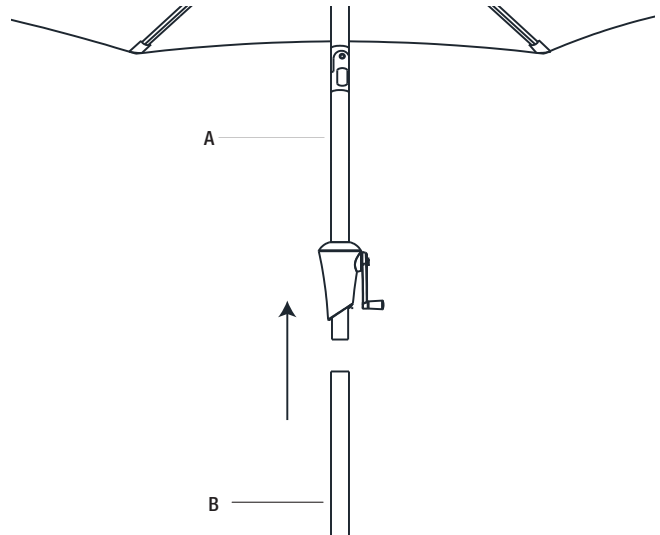

Operation

1 Open/Close the Canopy

- Turn the crank handle (1) in a clockwise direction to open the umbrella canopy (A), opposite direction to close the canopy (A). **THE UMBRELLA MUST BE IN THE UPRIGHT POSITION WHEN CLOSING.** Turn the crank handle in the clockwise direction and it will automatically tilt the umbrella to an angle. It will automatically come back to original position if turning the crank handle in the counterclockwise direction.

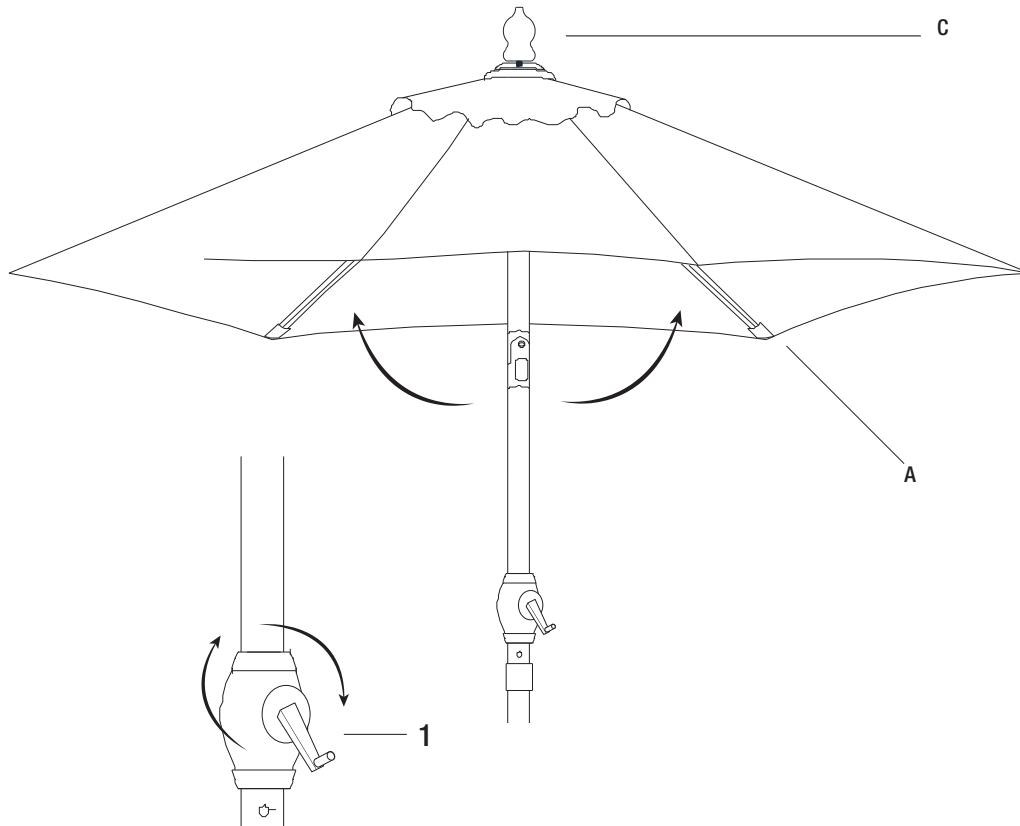

File a Claim

- If you are within your warranty, to file a claim you must have your receipt and pictures of the damaged part of your product. If filing a claim please contact us at 01 800 004 6633 or visit us through our website: www.homedepot.ca.

Care and Cleaning

- Simply clean the umbrella canopy with a soft brush and mild detergent.
- DO NOT machine wash or dry.
- DO NOT iron.
- AIR DRY the canopy thoroughly in an open position before storing for extended periods of time.
- FABRIC: 100% polyester
- Clean with damp cloth

Troubleshooting

| Problem | Possible Cause | Solution |
|---|---|---|
| The umbrella does not close | The top of the umbrella is in a tilted position. | □ Adjust the top of the umbrella top to be in the upright position and then to close the umbrella (See steps 1 and 2 in the operation section). |
| The crank does not click and the canopy does not move up when turning the crank handle in the open direction. | The rope is loose and needs to be wound around the crank shaft and stretched. | □ Keep turning the crank handle in the open direction several turns to wind and stretch the rope until the canopy moves up. |
| The crank becomes too hard to crank. | The rope has come off the pulley. | □ Slack the rope and put it back onto the pulley. |



Questions, problems, missing parts? Before returning to the store,
call Customer Service
8 a.m.-6 p.m., EST, Monday-Friday, 9 a.m. - 6 p.m., EST, Saturday

01 800 004 6633

HOMEDEPOT.COM

Retain this manual for future use.