

LIVING
accents

Malibu
5 pc High Dining Table
Assembly and User Manual
ITEM: FRN-103170C





NOTE: The schematics in this manual are for assembly and operation illustration only. They may differ from the chair's actual appearance.

LIVING
accents

www.atleisure.com
ATLANTA, GEORGIA
Customer Service Toll Free 1-855-880-7205
Monday through Friday from 8:00am-5:00pm
(Eastern Time)

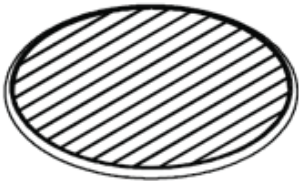
For additional product information, please contact our Customer Service Center at **1-855-880-7205** between 8am and 5pm Eastern Time, Monday through Friday.

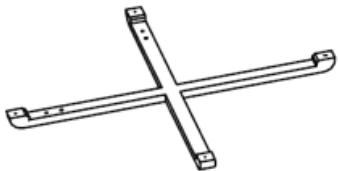
PICTURE	DESCRIPTION	QTY(PC)
A. 	Top Frame	1
B. 	Leg	4
C. 	Leg Brace	1

If you are within your warranty, to file a claim you **must** have your receipt and pictures of the damaged part of your product. Email information to us at **customerservice@atleisure.com** or contact us through the website: **www.atleisure.com**

| Caring For Your New Furniture

- Use mild soap and warm water to clean the frames. Rinse with clean water and dry thoroughly. Be sure to drain any water accumulated inside the frames. To thoroughly drain frames, remove footcaps and tilt frames, if necessary, to remove all water. Water allowed to accumulate inside the frames and then exposed to sub-freezing temperatures can cause damage to the frame tubing. Such damage is not covered under warranty. Any rust spots should be lightly sanded and treated with rust inhibitor and followed with an application of touch-up paint. Small nicks and scratches can be covered with an application of touch-up paint. Use commercially available glass cleaners, do not use abrasive materials, cleansers or bleach products. When not in use, protect your furniture with a Living Accents® outdoor furniture cover. Visit your local Ace Hardware store or www.acehardware.com for a wide product selection.

PREPARATION

Assemble product on a soft surface to prevent damage during assembly. Before assembling make sure all parts are present. Compare parts with package contents list and diagram above. If any part is missing or damaged, do not attempt to assemble the product. Contact our customer service representative for assembly assistance or questions toll free at 1-855-880-7205.

Tools Required for Assembly: Inner hexagon wrench included in package.

4. Instructions Of Set-Up & Operation |

1. Place the Top Frame(A) on a soft & clean level surface. Attach all 4 Legs(B) to Top Frame(A). Do not tighten the bolts too much.

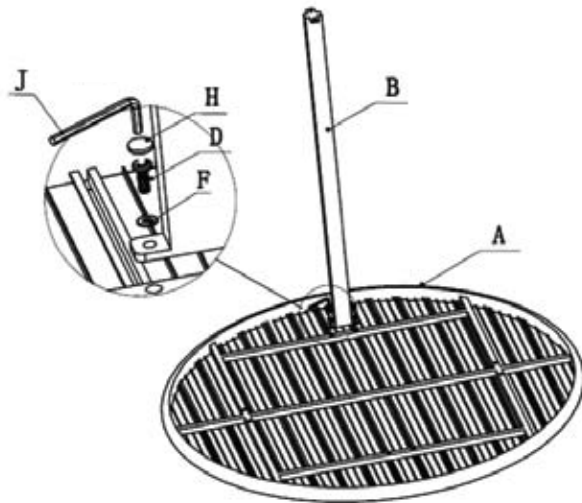

| Instructions Of Set-Up & Operation (cont'd) 5.

2. Attach the Leg Brace(C) to 4 Legs(B). Finally tighten up all the bolts.

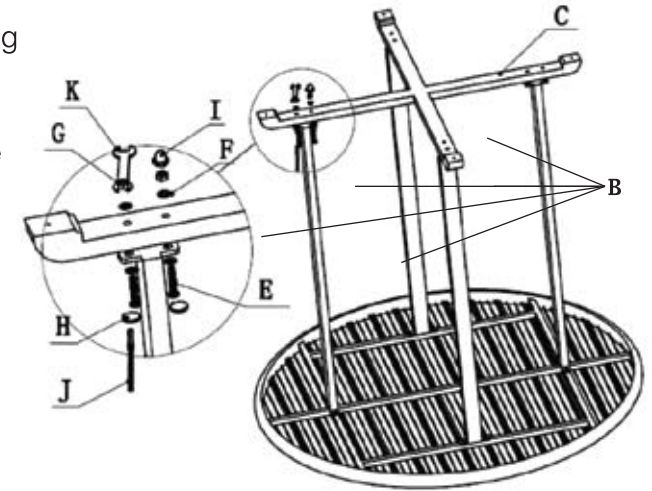









3. Turn the table over.



WHAT IS COVERED IN THIS WARRANTY? This product is covered under the Manufacturer’s Limited Warranty. To ensure your complete satisfaction, this warrants to the original purchaser that the frames and the frame construction, paint, finish, straps and wicker, and umbrellas are free from defects in material and workmanship and that it will, under normal use and proper care, remain so for one year after the date of purchase. Damage to frames or welds resulting from improper assembly or exposure to water and/or sub-freezing temperatures is not covered. General frame rusting is not covered. Umbrella bases are not covered under any circumstances. Replacement of missing or initially defective parts will be sent at no charge for a period of 10 days from the date of purchase. The Manufacturer and Ace Hardware will not be responsible for missing parts and/or hardware after 10 days from the date of purchase.

WARRANTY DOES NOT COVER: Freight and packaging charges to and from our customer service center remain the customer’s responsibility. Labor or material charges to remove or replace parts are not covered under this warranty. Furniture used for commercial purposes; failures caused by improper care; unreasonable or abusive use; damage by modification or alteration; freeze damage; acts of nature; rust; fabric stains; ripping or fading; purchased parts; or return freight and packaging charges are not covered under this warranty. Proof of purchase (dated register receipt) is required for warranty claims. All metal surfaces are protected with powder-coating process or a porcelain baking/high temperature painting process to prevent rust. Rusting is a normal occurrence when iron is exposed to the elements and is not included in the warranty. HOW TO OBTAIN SERVICE: For further information, please contact our customer service department, c/o ATLeisure at 855-880-7205 8:00a.m. to 5:00p.m., EST, Monday through Friday, or email us customerservice@atleisure.com.

PICTURE	DESCRIPTION	QTY(PC)
D. 	Bolt M6 x 15	8
E. 	Bolt (M6x35)	8
F. 	Washer	24
G. 	Hexagon Nut	8
H. 	Hexagon Nut Cap	16
I. 	Nut Cap	8
J. 	Innner Hexagon Wrench	1
K. 	Wrench	1